

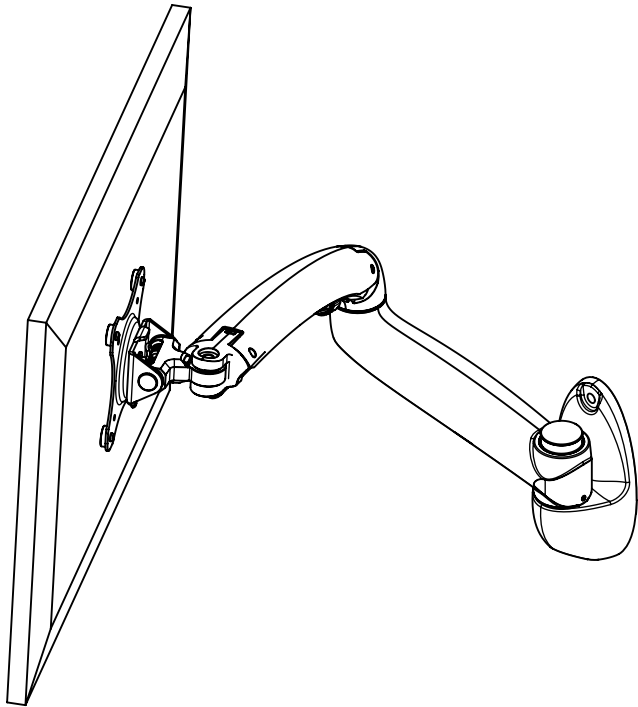

牆型 支架
牆型 支架
Wall Mount

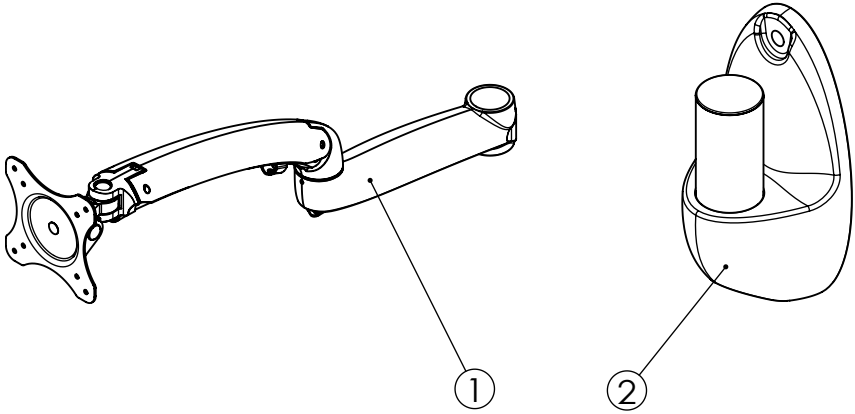

PC301
組裝說明書-V2
組裝說明書-V2
Installation Instruction-V2

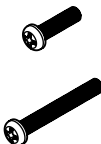
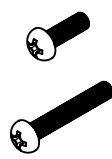

零件包編號 零件包编号 Part No.	單件編號 单件编号 Sub-part No.	單包數量 单包数量 Sub-part Qty.	規格 规格 Description	零件包數量 零件包数量 Part Qty.
N/A	1	1	牆型手臂組 墙型手臂组 Arm Set	1
	2	1	牆型底座組 墙型底座组 Wall Mount Set	1

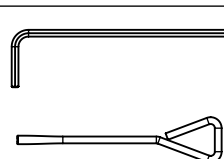
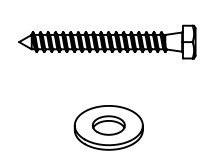
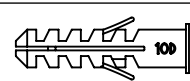
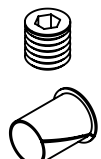
零件包編號 零件包编号 Part No.	單件編號 单件编号 Sub-part No.	單包數量 单包数量 Sub-part Qty.	規格 规格 Description	零件包數量 零件包数量 Part Qty.	
A-1	A-A	4	M4 x 15mm 螺絲 M4 x 15mm 螺丝 M4 x 15mm Philips Screw	1	
	A-B	4	M4 x 30mm 螺絲 M4 x 30mm 螺丝 M4 x 30mm Philips Screw		
A-2	A-C	4	M5 x 15mm 螺絲 M5 x 15mm 螺丝 M5 x 15mm Philips Screw	1	
	A-D	4	M5 x 30mm 螺絲 M5 x 30mm 螺丝 M5 x 30mm Philips Screw		
A-3	A-E	4	5mm 塑膠墊片 5mm 塑料垫片 5mm Spacer	1	
	A-F	4	10mm 塑膠墊片 10mm 塑料垫片 10mm Spacer		
B-1	B-A	1	3號六角扳手 3号六角扳手 3mm Allen Wrench	1	
	B-B	1	調整扳手 调整扳手 Adjustable Wrench		
C-1	C-A	2	尖尾螺絲 (8mm x 65mm) 尖尾螺丝 (8mm x 65mm) Lag Bolt (8mm x 65mm)	1	
	C-B	2	平面華司 (Ø8.5 x Ø18 x 1.5T) 平面华司 (Ø8.5 x Ø18 x 1.5T) Steel Washer (Ø8.5 x Ø18 x 1.5T)		
C-2	C-C	2	10D壁虎 (Ø8 mm x Ø10 mm) 10D壁虎 (Ø8 mm x Ø10 mm) 10D Anchor (Ø8 mm x Ø10 mm)	1	
D-1	D-A	1	M6 x 5mm止付螺絲 M6 x 5mm止付螺丝 M6 x 5mm Socket Set Screw	1	
	D-B	1	調整管手臂軸套 调整管手臂轴套 Adjustable Arm Sleeve		

步驟一：將A-1或A-2螺絲照圖依序穿過①、A-3塑膠墊片再鎖入電腦螢幕鎖緊固定。
(因電腦螢幕的VESA孔深度大不相同，所以塑膠墊片&螺絲請視情況選擇使用款式)

步驟一：將A-1或A-2螺絲照圖依序穿過①、A-3塑料墊片再鎖入计算机屏幕鎖緊固定。
(因计算机屏幕的VESA孔深度大不相同，所以塑料墊片&螺絲請視情況選擇使用款式)

Step 1 : Use A-1 or A-2 screws for the arm set, and use A-3 5mm or 10mm spacers between the arm set and the monitor. (Due to the depth of the VESA hole may be various, please select the suitable spacers and screws.)

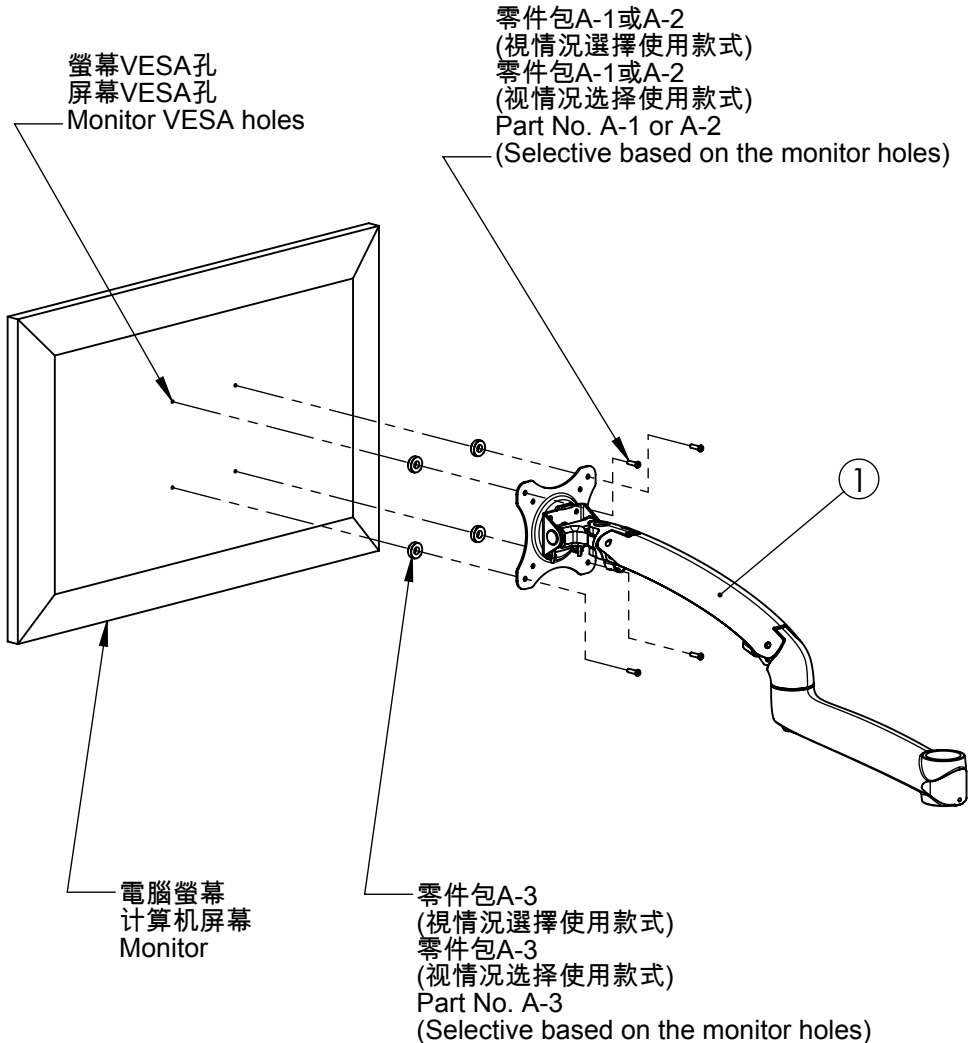

步驟二：先將②貼於牆壁適當位置上，用筆於掛壁孔上畫點做鑽孔記號。(孔距152mm)

步骤二：先将②贴于墙壁适当位置上，用笔于挂壁孔上画点做钻孔记号。(孔距152mm)

Step 2 : Mark the holes of the wall mount set on the concrete wall. (Hole distance: 152mm)

步驟三：依牆壁上的記號點用 $\varnothing 3/8"$ (10 mm)水泥鑽頭鑽孔約60mm深

步骤三：依牆壁上的记号点用 $\varnothing 3/8"$ (10 mm)水泥钻头钻孔约60mm深。

Step 3 : Drill $\varnothing 3/8"$ (10 mm) holes about the depth of 60mm on the wall.

步驟四：再將C-C敲入牆壁剛鑽好的孔內。

步骤四：再将C-C敲入墙壁刚钻好的孔內。

Step 4 : Insert C-C anchors into the holes.

步驟五：最後將C-A依圖穿過C-B、②再鎖入至C-C內完成。

步骤五：最后将C-A依图穿过C-B、②再锁入至C-C內完成。

Step 5 : Screw the wall mount set on the wall by C-A bolts and C-B washers.

※ 若安裝於木牆時則用 $\varnothing 7/32"$ (5 mm)鑽頭鑽孔約60mm深，C-C不需使用。

※ 若安装于木墙时则用 $\varnothing 7/32"$ (5 mm)钻头钻孔约60mm深，C-C不需使用。

※ Install ② on wood wall.

Drill $\varnothing 7/32"$ (5 mm) holes about the depth of 60mm on the wall.

There is no need to use C-C.

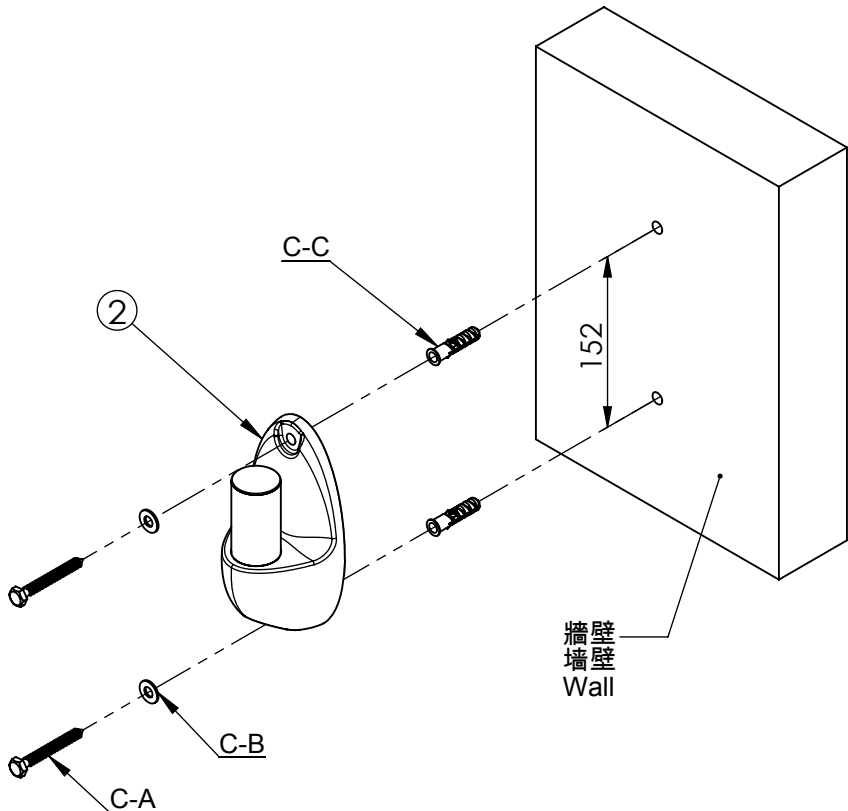

步驟六：再將D-B依圖套入至①孔內到底。(注意圖示缺口方向)

步驟六：再将D-B依图套入至①孔内到底。(注意图示缺口方向)

Step 6 : Install D-B sleeve into the hole of the arm set. (Note the sleeve gap location)

步驟七：最後將①整組套入至②管內後用D-A鎖緊即完成。

步驟七：最后将①整组套入至②管内后用D-A锁紧即完成。

Step 7 : Inset the arm set into the wall mount set, and tighten the arm set by D-A screw.

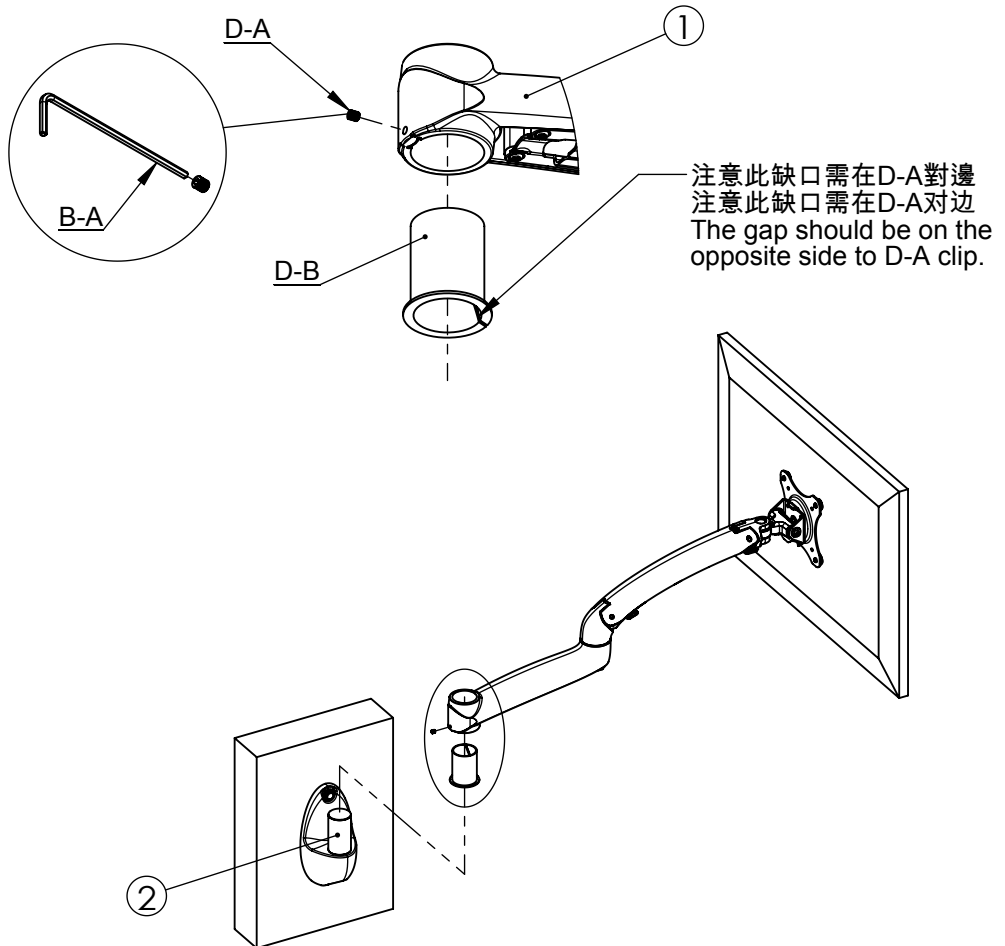

註：產品組裝完畢後請視螢幕重量使用B-B調整"彈簧調整塊"，重螢幕往"H"方向調整，輕螢幕往"L"方向調整。

注：产品组装完毕后请视屏幕重量使用B-B调整"弹簧调整块"，重屏幕往"H"方向调整，轻屏幕往"L"方向调整。

Remark : After the installation, please use B-B wrench to adjust the spring adjusting block based on the weight of the monitor.
"H" is provided for the heavy monitor and "L" is provided for the light monitor.

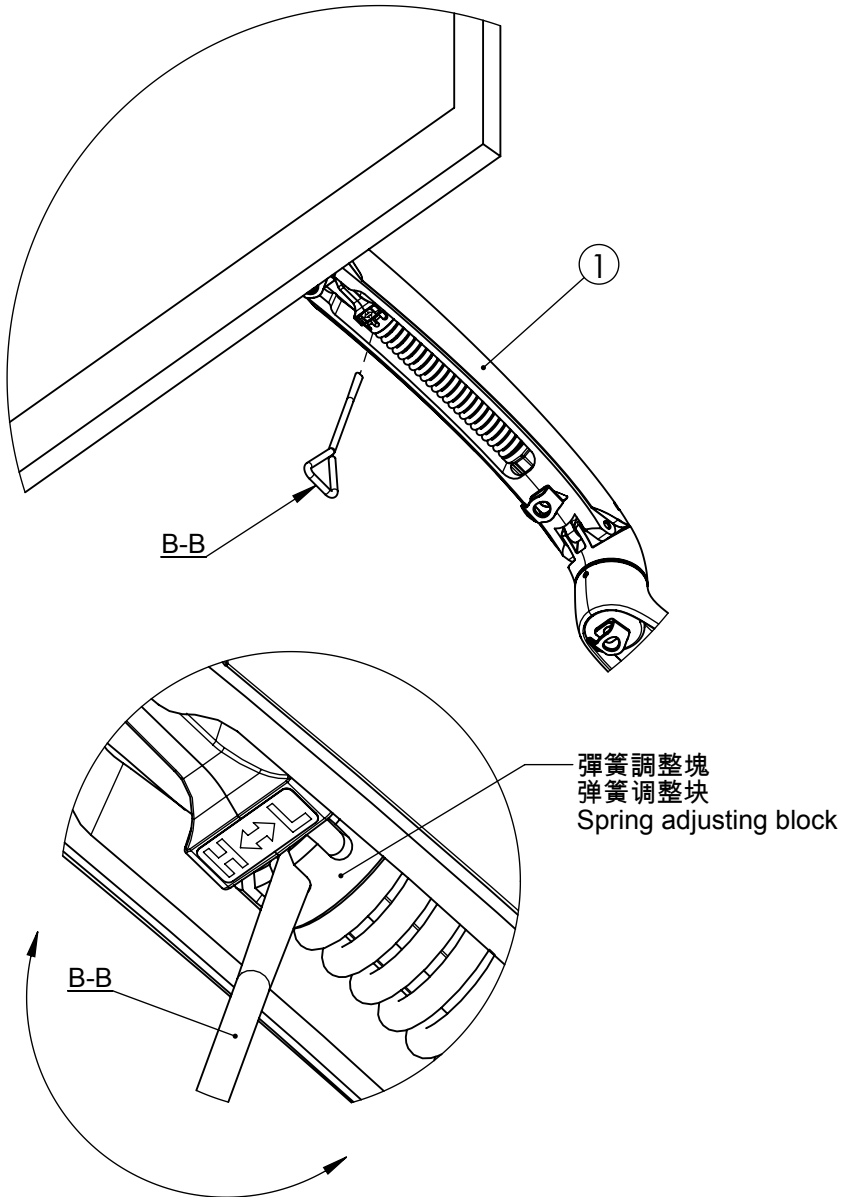

組立完成圖
組立完成图
Assembly completed

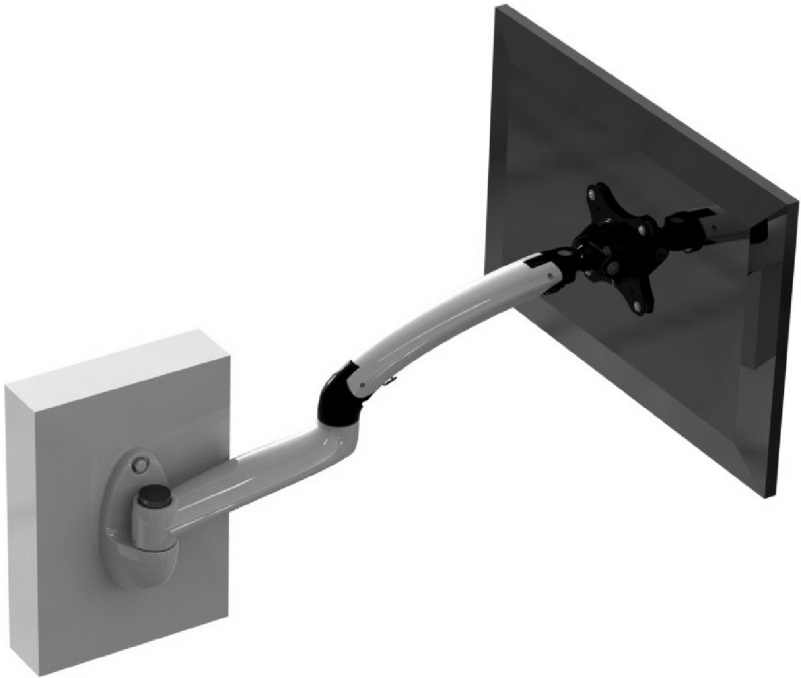
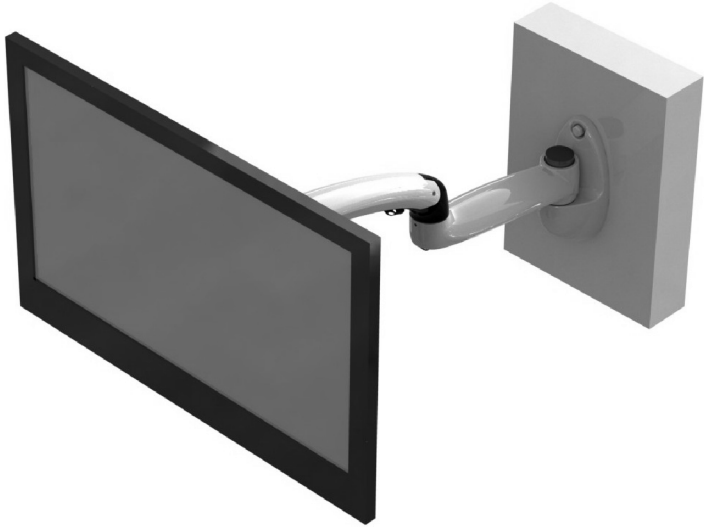

- ※ 手臂拉伸距離會因彈簧依螢幕調整而有些差異
- ※ 手臂拉伸距離會因彈簧依螢幕調整而有些差異
- ※ The distance of the arm stretch is depending on the spring tension adjusted for different weights of monitors.

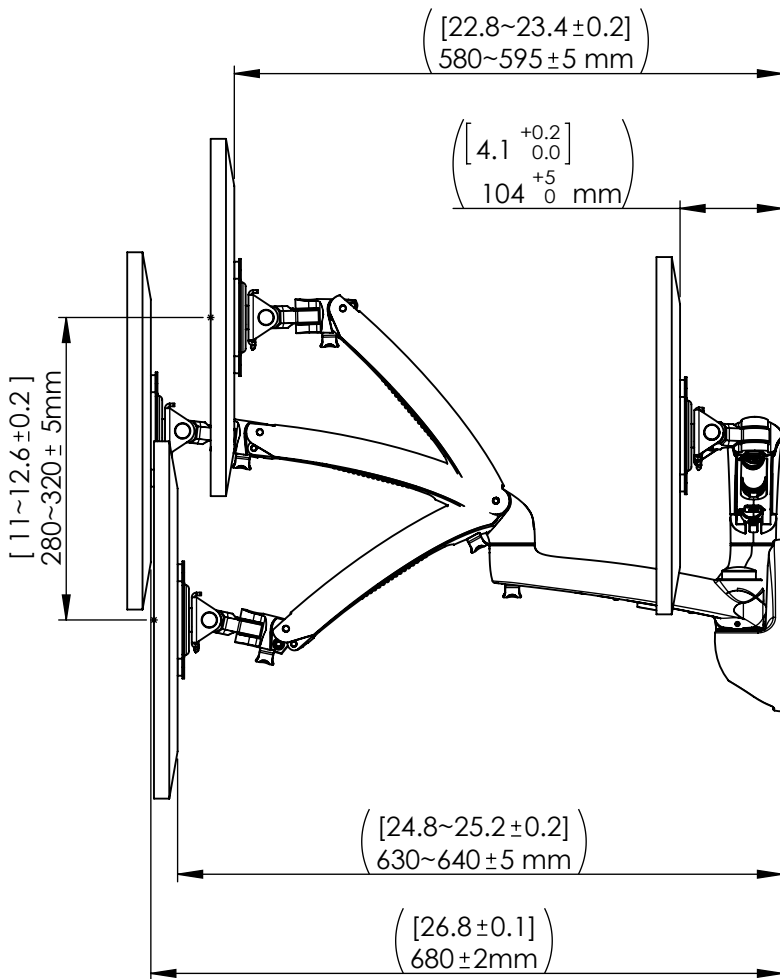

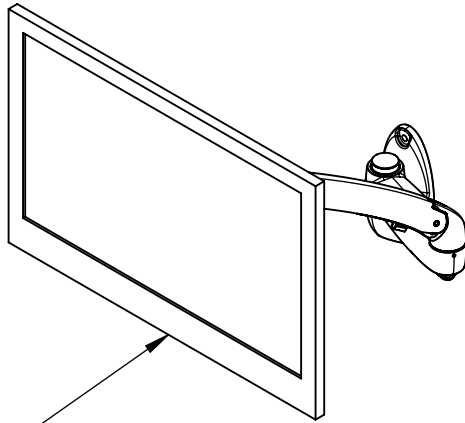

螢幕 $\leq 27''$
屏幕 $\leq 27''$
Monitor $\leq 27''$
3.8~8.1kg

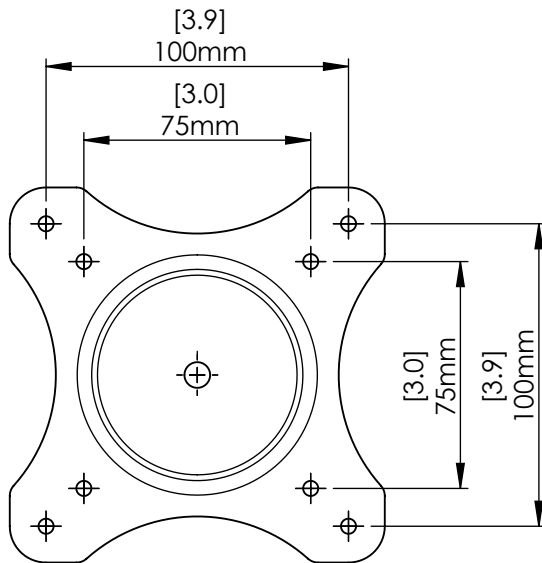

VESA

- ※ 以下角度以一般平面螢幕為基準，實際角度還是要依安裝的螢幕而定。
- ※ 以下角度以一般平面屏幕为基准，实际角度还是要依安装的屏幕而定。
- ※ Below angles are estimated for general monitors.
Actual angles would depend on the monitor in use.

