

CDG
Your Professional Guide to
Office | Home | School
Wellness and Ergonomic Care



<https://www.cdgreat-officefurniture.com/>

No. 526, Section 1, Shenlin Road, Daya District,
Taichung City Taiwan 42865

+886-4-25679181

cd.great@msa.hinet.net

Find us on   

20 years of OEM & ODM furniture
manufacturer from Taiwan. Specialize
in metal parts, goods and end
products.

 **CD Great Industry Co, Ltd**



Company profile

C.D. Great Industry Co., Ltd. was founded in 2002 with a priority on high-quality ergonomic products that improve people's wellness, comfort and productivity. We have experience, capability, and R&D resources to develop and manufacture OEM and ODM products. We also provide comprehensive solutions for clients to refine the design, streamline manufacturing process to reduce costs, making designs possible for manufacturing and appropriate for marketing.

Our products are manufactured under a strict control program with ISO9001 certified. In order to meet each customer's expectation, every step of the manufacturing process is monitored under supervision including incoming material inspection, processing and product inspection, final-product inspection, packaging regular check-ups so that quality and safety standard is guaranteed. Our mission is to provide high-quality products and efficient service with the most innovative designs and attractive prices to our worldwide customers.

Introduction to OEM Capability

OEM/ODM Service

CDG is a professional OEM/ODM service provider, we own years of experience in design and manufacturing.

We offer ergonomic design and verification services for creating a series of innovative products. Cost effective and quality products are what we are concerned for our clients. With quality control laboratory and production management ability, we can be your reliable partner.



ESTABLISHED IN 2002

R&D Capability

- Customized product design
- Prototype development and verification
- Product packaging design



BASED IN TAIWAN

Manufacturing Capability

- 600 containers shipped a year
- Good quality assured in mechanical structure
- Assembly ability for easy installation to end users



QUALITY ASSURED

Quality Control

- Various Inspection Equipments for different testing, including Projection comparator, RoHS Analyzer, fatigue, hardness and endurance capability testers to ensure the best quality provided
- Strict quality inspection for incoming material and finished goods
- Quality assurance is maintained at each step of production
- Products are manufactured under a strict control program with ISO 9001 certified

Our Production Facilities



Metal Pressing



Powder coating



Laser Cutting



Metalworking

*Professional in OEM&ODM service,
located in Taiwan.*

*Specialize in metal parts, goods and
end products.*



Metal Fabrication



Corrosion



Product Inspection Weight Check



Cycle Testing Machine 3



RoHS Tester

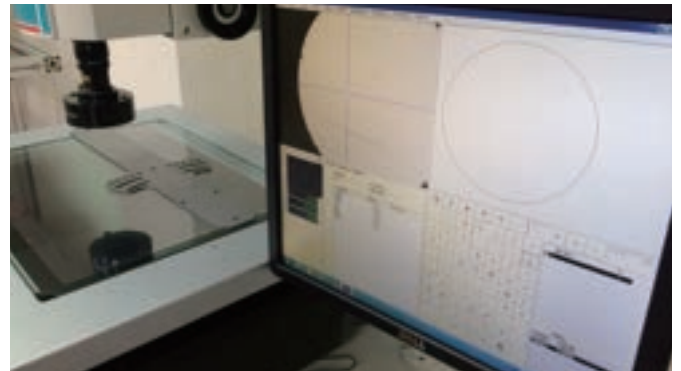

3D Printer



Horizontal Measurement Instrument

Dia. 300mm / Dia. 600mm

Certificate TW10/00310

The management system of

C.D. Great Furniture Co., Ltd.

No. 526, Sec.1, Shen Lin Rd., Da Ya Dist., Taichung City 428, Taiwan R.O.C.

has been assessed and certified as meeting the requirements of
ISO 9001:2015

For the following activities

Design, Assembling and Sale of TV Stand, TV Mounting Bracket and Furniture.



This certificate is valid from 28 June 2022 until 28 June 2025 and remains valid subject to satisfactory surveillance audits.
Issue 6. Certified since 28 June 2010.

Authorised by

SGS United Kingdom Ltd
Rossmore Business Park, Ellesmere Port, Cheshire, CH65 3EN, UK
t +44 (0)151 350-6666 - www.sgs.com



This document is issued by the Company subject to its General Conditions of Certification Services accessible at www.sgs.com/terms_and_conditions.htm. Attention is drawn to the limitations of liability, indemnification and jurisdictional issues established therein. The authenticity of this document may be verified at <http://www.sgs.com/en/certified-clients-and-products/certified-client-directory>. Any unauthorized alteration, forgery or falsification of the content or appearance of this document is unlawful and offenders may be prosecuted to the fullest extent of the law.





ED02 2-leg Height Adjustable Desking Frame

Weight Capacity	Up to 220 lbs / 100 kgs
Worktop fitting sizes	42- to 72-inch wide
Table width	34" / 863 mm to 64" / 1625 mm
Height Adjustable Range	660 mm (Stepless)
Height	595 mm to 1255 mm
Speed	30 mm / per second
Frame	Steel



SP401 CPU PC Holder

Head Connecting Piece Swivel	360°
Material	Aluminum
Weight Capacity	22 lbs/ 10 kgs
Width	90-240 mm
Height	365-565 mm



Height Adjustable Table

CDG's electric height adjustable desk frame series come with a sleek and sturdy structure which is height adjustable, width expandable and durable. We offer a desking solution for hassle-free setup with lifting technology incorporated and movement controlled by an easy fingertip touch. With the smart control Memory Function, it is remarkably easy to switch between sitting and standing or any preferable height without interrupting workflow. Simply just pick a desktop and you are all set to go!



ED03 3-leg Height Adjustable Desking Frame

Weight Capacity	Up to 330 lbs / 150 kgs
Table Frame Opening Closure	90° OR 120°
Width	50.2" / 1275 mm to 80.2" / 2037 mm
Height Adjustable Range	660 mm (Stepless)
Height (Table leg)	23.4" / 595 mm to 49.4" / 1255 mm
Speed	30 mm / per second
Desk Frame	Steel

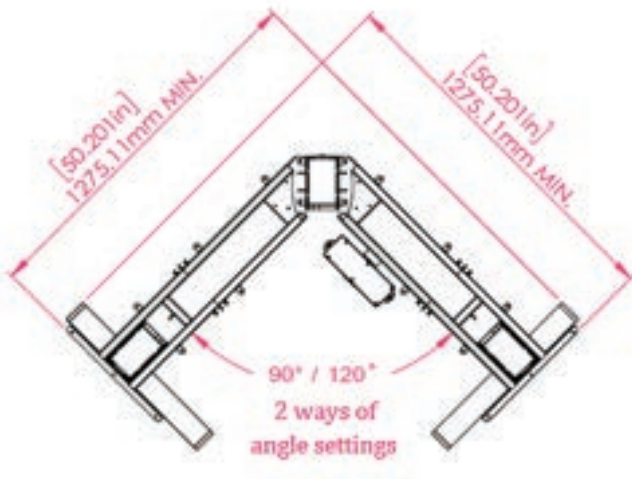



OL001 Sit-Standing, Height Adjustable, Fliptop and Folding Big Table Desk

Material	MDF+ Melamine Laminate
Desktop Dimension	1,500mm X 700mm
Desktop Thickness	18mm
Height	75cm~105cm(±1cm)
Color	White
Base Height	132mm
Base Material	Iron, Plastic, Rubber
Caster Size	2"
Weight Capacity	50kg
Column Material	Aluminum, Iron, POM
Total Weight	48kg



OL002 Mobile Height Adjustable Table with Drawer on Wheels for Student, School and Office Use

Desktop Material	MDF+ Melamine Laminate
Desktop Dimension	700mm X 500mm
Desktop Thickness	18mm
Height	74cm ~ 117cm(±1cm)
Color	White
Base Height	143mm
Base Material	Iron, Plastic, Rubber
Caster Size	2"
Weight Capacity	50kg
Column Material	Aluminum, Iron, POM
Total Weight	19.22kg



HC101 Mobile Height Adjustable Electric Laptop Table Desk on Wheels

Desktop Material	MDF + Melamine Laminate
Desktop Dimension	600mm X 400mm
Desktop Thickness	18mm
Height	67.6 cm ~ 107.6 cm(±1cm)
Color	White
Base Height	53mm
Base Material	Iron& ABS
Caster Size	2"
Weight Capacity	20kg
Column Material	Aluminum, Iron& POM
Lifting Speed	28.8mm/sec
Total Weight	14.9kg



HC103 Mobile Height Adjustable Electric Laptop Table Desk with Keyboard Tray on Wheels

Desktop Material	MDF + Melamine Laminate
Desktop Dimension	110cm X 60cm
Desktop Thickness	18mm
Keyboard Dimension	630mm x 240mm
Keyboard Thickness	15mm
Height	73cm ~ 118cm(±1cm)
Color	White
Base Height	68mm
Base Material	Iron, Plastic
Weight Capacity	50kg
Column Material	Aluminum, Iron, POM
Total Weight	28.8kg

